

# TF 38.10 TT MIT GABELN

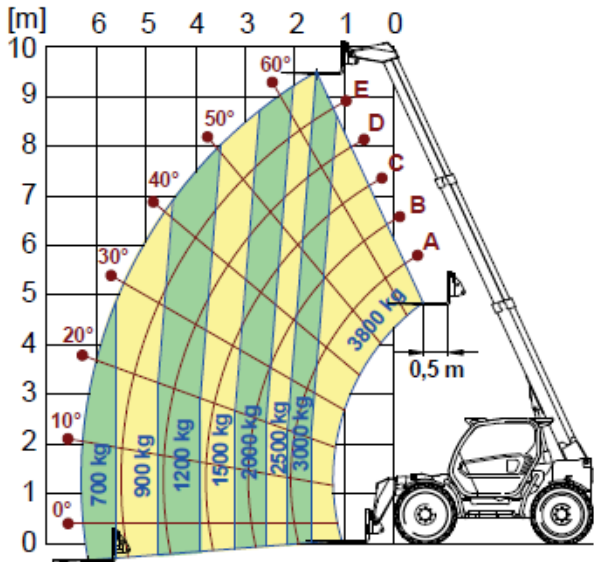

EN 1459/B

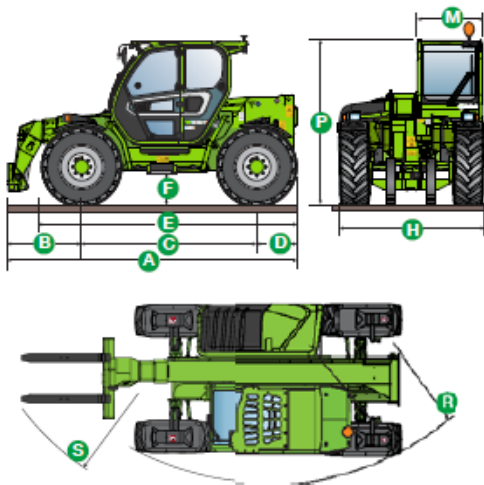

## ABMESSUNGEN 42.7 / 38.10

A (mm)	4520	4560
B (mm)	1125/1075*	1165/1115*
C (mm)	2750/2800*	2750/2800*
D (mm)	645	645
E (mm)	3926/3976*	3926/3976*
F (mm)	460	460
H (mm)	2250	2250
M (mm)	1010	1010
P (mm)	2490/2550**	2490/2550**
R (mm)	3985	3985
S (mm)	4800	4800